

### TWA-100 Tank Weigh Assembly

A simple and accurate weigh assembly, the TWA-100 Tank Weigh Assembly can be used for any weighing scenario where a load is applied from above.

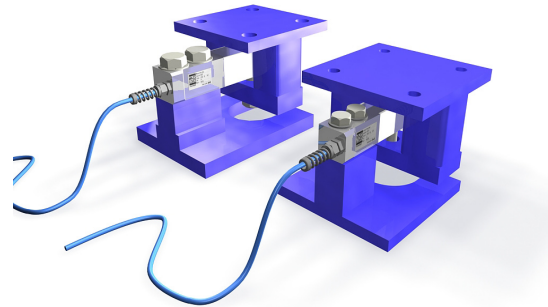

#### Capacity ranges

- 1,000lbs, 2500lbs, 4,000lbs
- 5,000lbs, 10,000lbs



#### TWA-100 Performance Specifications

Safe Overload .....	150% FS
FS Output .....	3mV/V +/- .25% FS
Max Excitation .....	15 VDC
Non-Linearity .....	<0.03% FS
Hysteresis .....	<0.02% FS
Therm Sens Shift .....	0.0008% of reading/°F
Therm Zero Shift .....	0.0015% FS/°F
Barometric Effect .....	nil
Bridge Resistance .....	700Ω
Operating Temp Range .....	-50°C to +80°C
Compensated Temp Range .....	-10°C to +40°C
Sealing Standard .....	IP-67

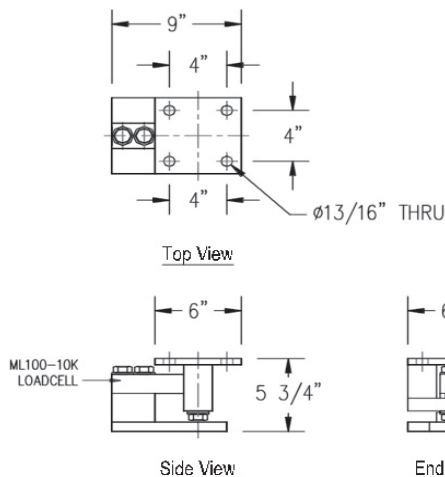

TWA-100 5K-10K Capacity  
 Finish: Massload Blue

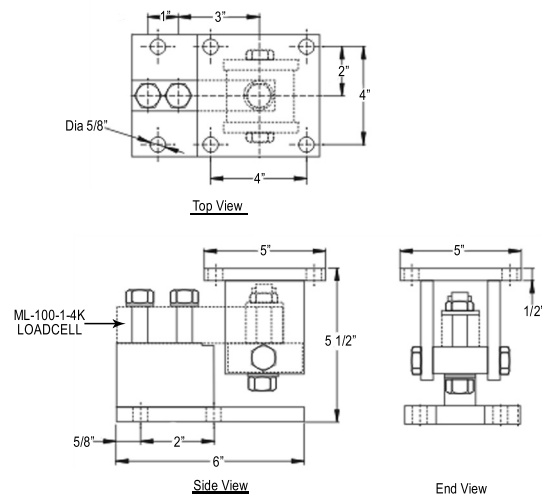

TWA-100-1K-4K Capacity  
 Finish: Nickel Plated